

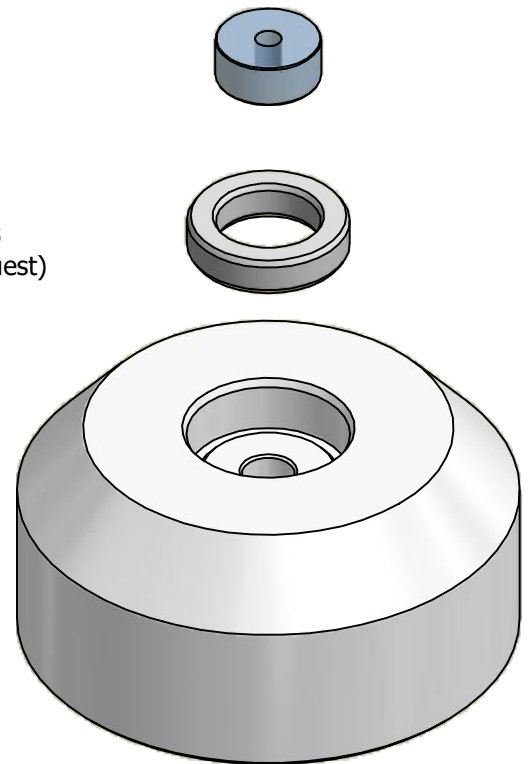

Holder: Stainless steel AISI 303
 Orifice: Sapphire (Ruby on request)



Cotes en mm; Tol. en μm		Matière :		Echelle 10:1				
[Cotes en in; Tol. en μin]		Traitement :						
ISO 2768-mK		Désignation						
		Assembly 9506 PA						
Dessiné:	01.03.2017							
Approuvé:	22.06.2017							
		N° de plan		Révision	Page			
		451 / Assembly 9506 PA		A	1 / 1			